

BLE to DALI Ceiling Mounted AC PIR Sensor With 10A Relay

CLX-SV9030D-PIR-10AD

Features

- Bluetooth to DALI sensor controller
- Bluetooth® NLC Certified
- Mesh network, which has a much longer control distance, transmits received signals to neighboring devices
- All devices on DALI line are broadcast controlled by mobile application
- Supports our kinetic energy switches and EnOcean switches EWSSB and EWSDB
- Autonomos sensor-based control
- Mesh Range over 40m at open area
- Supports sensitivity adjustment, Mesh Network, a better method to deal with false trigger
- Recessed mounted/ Surfaced-mounted application
- Available with Magnetic reset (touch "OPEN" on the sensor top for 5 seconds)*
- On-board antenna
- IP44, recommend indoor application
- 5 years warranty

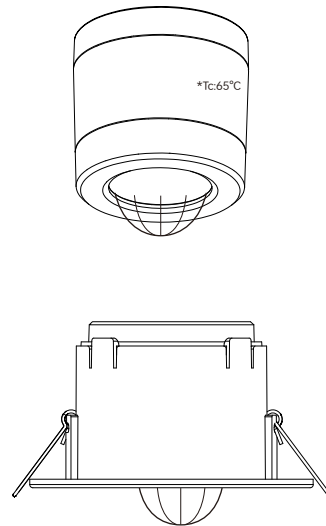

* With Recessed-Mounted Kit
(Optional for order)

Parameters

Input & Output Characteristics	
Operating voltage	220 ~240VAC 50/60Hz
Stand-by power	<0.5W
Relay	Max.10A, 400W LED

Safety & EMC	
EMC standard (EMC)	EN55015, EN61000, EN61547
Safety standard (LVD)	EN60669-1, EN60669-2-1 AS/NZS60669-1/-2-1
RED	EN300328, EN301489-1/-17
Certication	ENEC, CE, EMC, RED, RCM

Sensing	
Movement detection	Typical.10m @ 3m height
Installation	Max.6m



Environment Parameters	
Operation temperature	Ta: -20°C ~ +50 °C
IPrating	IP44(Front-face) IP44 (With surface mount kit)

Mechanical Data	
Dimension	φ90*52mm(without surface kit)
Material	Flame-retardant/ABS
Protection Class	Class II

Connectors	
Terminal block/Wire size	0.5mm ² - 1.5mm ² solid or stranded
Wire strip length	6-7mm

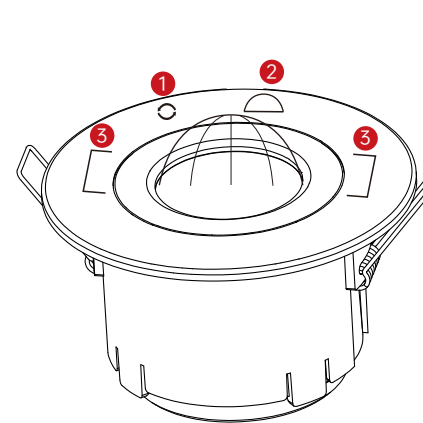
Product info



- ①  Magnetic reset. Using magnet close this icon over 5s. Reset successfully, LED quick flash.
- ②  Semi-circular detection pattern icon
- ③  Corridor detection pattern

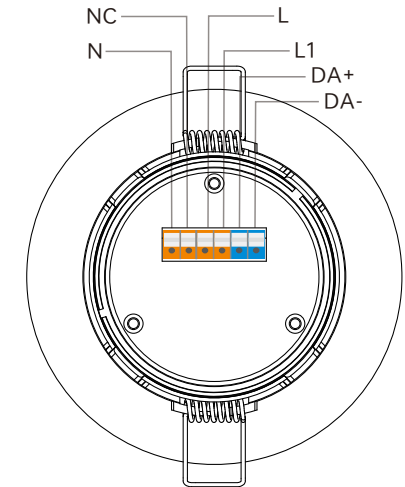

Dimension

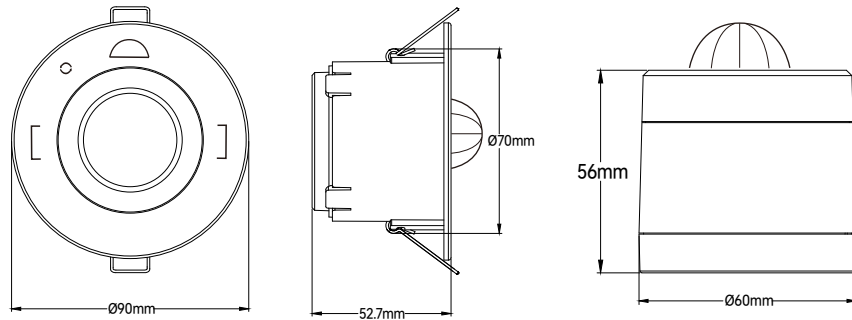

Wiring

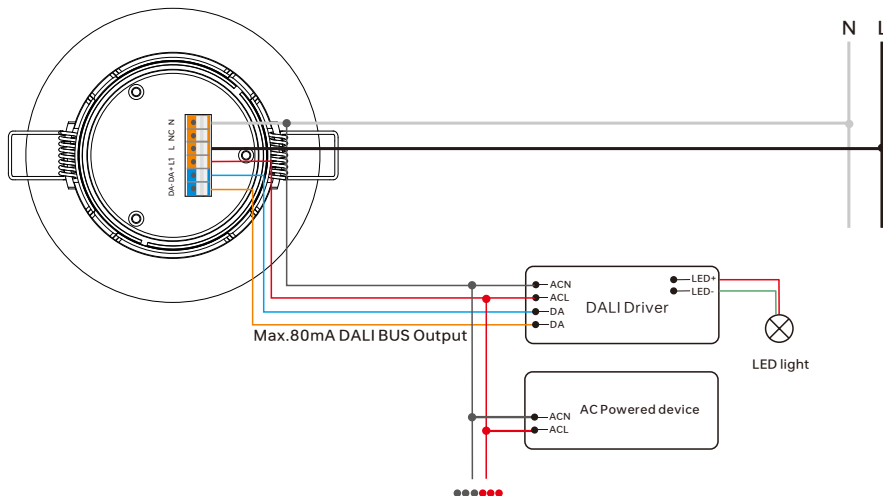

Application

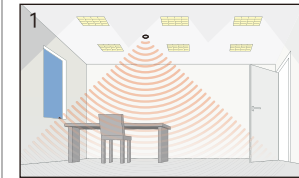

1. Power up the sensor. The load should come on immediately.

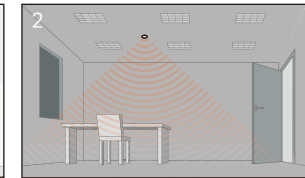

2. Vacate the room or remain very still and wait for the load to switch off.

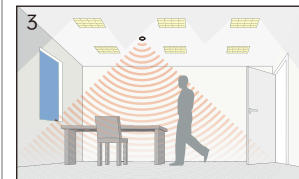

3. Enter the room or make some movement and check that the load switches on.

PRECAUTIONS

- Do not place the SENSOR near heat sources, fans or in ventilated ceiling voids.
- Do not place close to, or positioned such that, any light source points directly into the SENSOR.
- Ensure wires and cables are securely held within the connection terminals.
- Disconnect the SENSOR from the circuit before performing insulation testing of the wiring circuit.

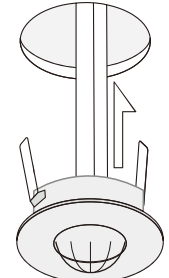

Bend the springs up and push detector through hole in ceiling. When fully inserted the springs snap back to hold the device in place. To avoid injury, take care when bending springs.

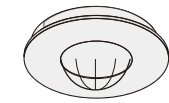

Installation complete.

Specification

ENERGY SAVINGS

- Low/High-end trimming
- Daylight harvesting
- Occupancy/Vacancy detection
- Auto and advanced demand response programs
- Time-of-Day dimming schedule
- Energy monitoring

COMFORT & CONVENIENCE

- Advanced occupancy detections
- Light-level stability
- Configurable dim-and-linger occupancy
- Personalized setting profile
- Work with kinetic switch keypad and dimmer wallstation
- Multi-scenes control

Accessory

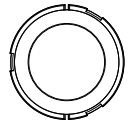

No-Block Lens Mask
(Default)

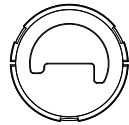

Semi-Circular Lens Mask

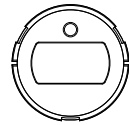

Corridor Lens Mask

1) No-Block Lens Mask

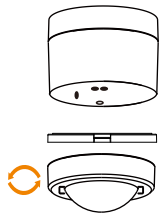

No-Block Lens Mask

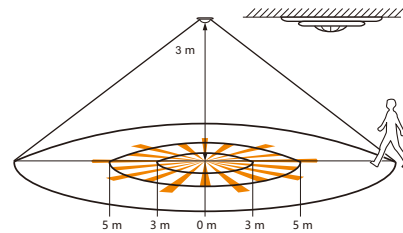

With No-Block Lens Mask: ϕ 8-10m at 3m height

1. Turn the sensor cover counterclockwise and put the **No-Block Lens Mask** in.
(Please ignore it if it is already **No-Block Lens Mask**.)

2) Semi-Circular Lens Mask

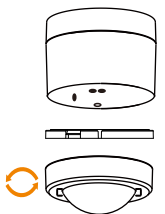

Semi-Circular Lens Mask

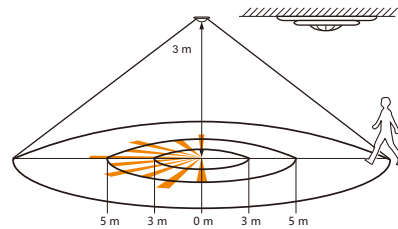

With Semi-Circular Lens Mask: Half-detection pattern

1. Turn the sensor cover counterclockwise and put the **Semi-Circular Lens Mask** in.
(Please ignore it if it is already **Semi-Circular Lens Mask**.)

3) Corridor Lens Mask



Corridor Lens Mask

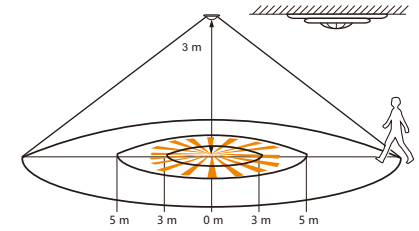

With Corridor Lens Mask: ϕ 6-7m at 3m height

1. Turn the sensor cover counterclockwise and put the **Corridor Lens Mask** in.
(Please ignore it if it is already **Corridor Lens Mask**.)

More Infos

- 1) Average Input Current: < 30mA
- 2) Standby-power consumption: < 0.5W
- 3) Power Consumption: < 1W
- 4) Max Tx Power: +8dBm
- 5) Number of connected drivers: Up to 64 contol gears (Broadcast control)
- 6) Status Indicator: Red-Movement detection; Green-Network status
- 7) Detection range: ϕ 10m@3m Height @ Default sensitivity
Detection Angle: 127°
Operating Range (Light sensor) : 1-1000Lx
Light Sensor Accuracy: \pm 20%
- 8) Built-in type: IP44(Front-Face), Class III, ta 45°C, tc 55°C
- 9) Operating temperature: -20°C-50°C
Storage temperature: -25°C-60°C
Operating humidity: 0-80%(non-condensing)
- 10) Expected Lifetime: More than 5 years.
- 11) BT NLC certified
- 12) Nordic Chipset: nRF 52840

Detection Pattern

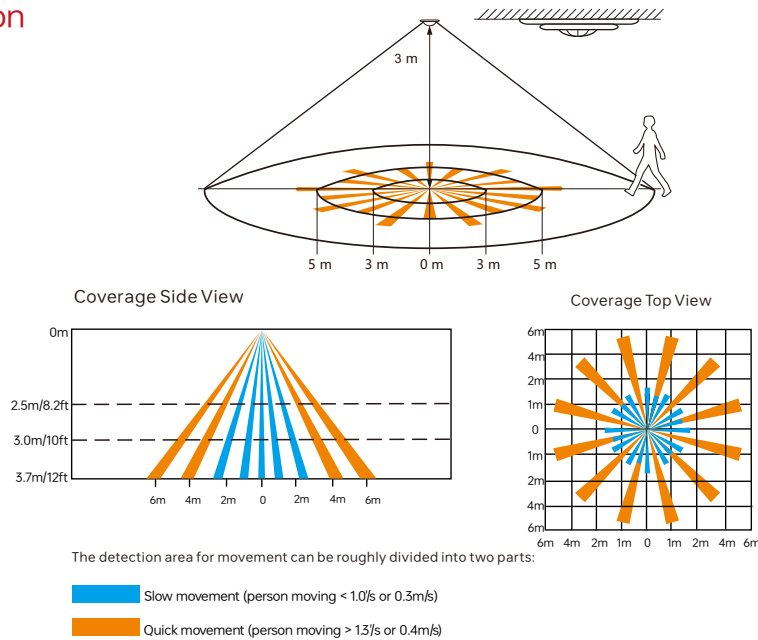

Detection Range

- Note:
- Following different detection areas are based on different installation heights & patterns.
 - Detection Pattern is a relevant value, the performance should depend on the site conditions (installation height/ temperature/ sunlight/ humidity/ Blind area...etc)

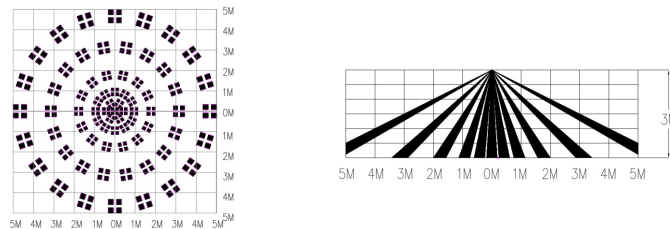

Recommend User Application

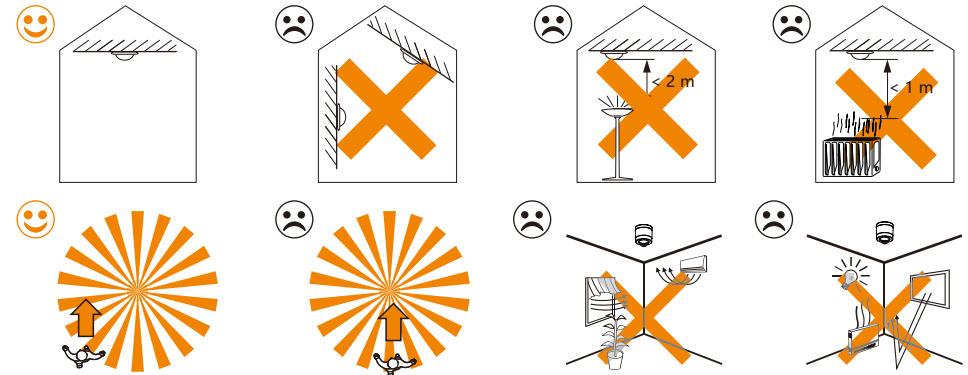

Installation Precautions

- Avoid areas with frequent temperature changes: Keep away from air conditioners, fans, refrigerators, ovens, and other objects that cause rapid temperature changes. The detection effectiveness of PIR motion sensors is closely related to temperature fluctuations, and vents or heat sources can lead to false alarms.
- Avoid areas with significant air flow.
- Avoid facing glass doors and windows directly: 1) Do not face glass doors and windows directly to avoid interference from strong light. 2) Avoid complex environments outside doors and windows, such as direct sunlight, crowds, and moving vehicles.
- Avoid installing opposite large, constantly moving objects: Large objects with significant motion can cause sudden changes in airflow within the detection area, leading to false alarms. Outdoor PIR motion sensors should not be installed opposite large trees or tall bushes.
- Avoid areas with screens, furniture, large potted plants, or other obstacles within the detection range.
- Avoid areas exposed to direct sunlight.

Update Log

Date	Version	Update Content	Update by
2025-8-14	V1.2	Parameter Update	Romeo

Subject to change without notice. Please contact us if you have any questions.