

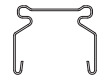





Compatible list

Table 1

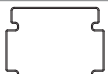
Trunk rail Model	Trunk	Connectors-3pin	Connectors-5pin
TRX TRZ		wago 267-113	/
090554/098287		wago 267-113	/
ZX1 T8		3pin-plug ZX1	/
ZX2 T8		3pin-plug ZX2	5pin-plug ZX2
PRESTIGE T8		3pin-plug ZX2	5pin-plug ZX2
E-line 07690xx		wago 267-163	wago 267-165
SDT/ST		wago 267-163	wago 267-165
TR50W		wago 267-163	wago 267-165
SV70 SV75		wago 267-163	wago 267-165
Planos		wago 267-163	wago 267-165
PNR 2003-nu		wago 267-163	wago 267-165
PNR 1995-2003		wago 277-126	/
E-STN T8		wago 277-126	/
TTX400 T8		3pin-Plug PH	5pin-Plug PH
MAXOS T8		3pin-Plug PH	5pin-Plug PH

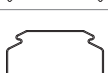
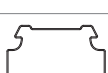
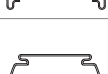
Calex Renovum NXS Installation Manual

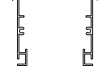
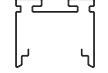
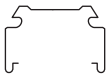
IMPORTANT SAFETY NOTES



WARNING
RISK OF ELECTRIC SHOCK

BEFORE YOU BEGIN

- Read these instructions completely and carefully.
- The installation and connection of the luminaire must be done when switched off and by qualified people. Make sure no voltage while installation.

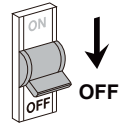

CAUTION

MAINTENANCE

- To avoid injuries, disconnect power to the light and allow the unit to cool down before performing maintenance.
- Perform visual, mechanical and electrical inspections on a regular basis. We recommend routine checks to be made on an annual basis. Frequency of use and environment should determine this.
- The Covers should be cleaned periodically as needed to ensure continued photometric performance. Clean the Cover with a damp, non-abrasive, lintfree cloth. If not sufficient, use mild soap or a liquid cleaner. Do not use an abrasive, strong alkaline or acid cleaner as damage may occur.
- Inspect the topside on the luminaire to ensure that it is free of any obstructions or contamination (i.e.excessive dust build-up). Clean with a non-abrasive cloth if needed.



This product contains a light source of energy efficiency class D.

Products

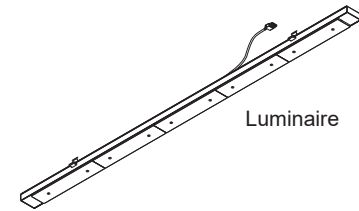

Optional Accessories

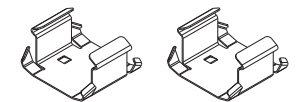

Special extra spring

Optional

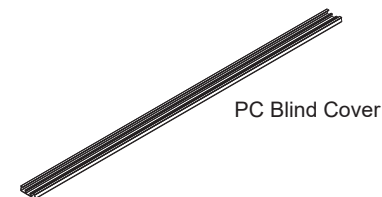

Optional Accessories

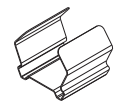

Special extra spring

Optional Plug

3-Pin

5-Pin

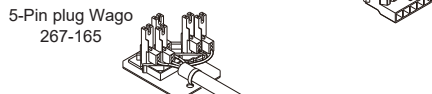
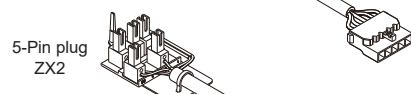
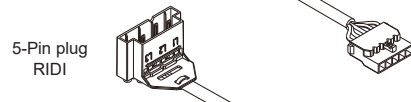
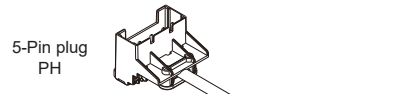
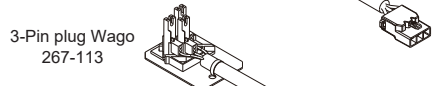
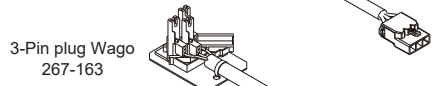
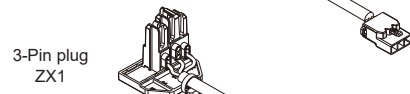
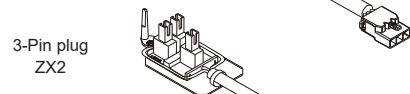
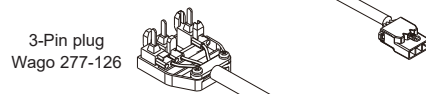
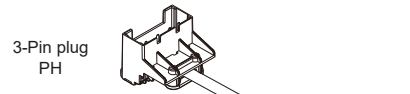

Installation PC Blind cover

1 Cut to desired length
(Option)

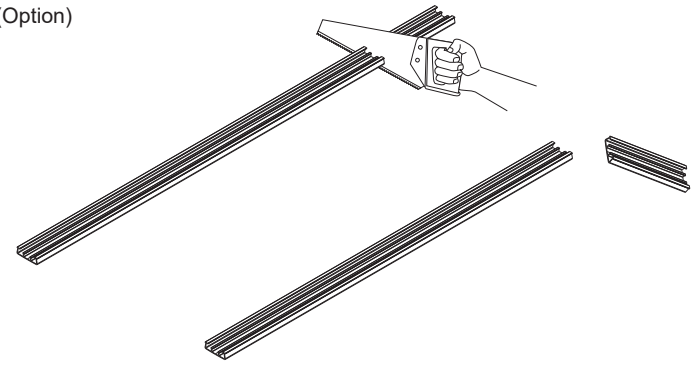

2 Mounting Blind Cover

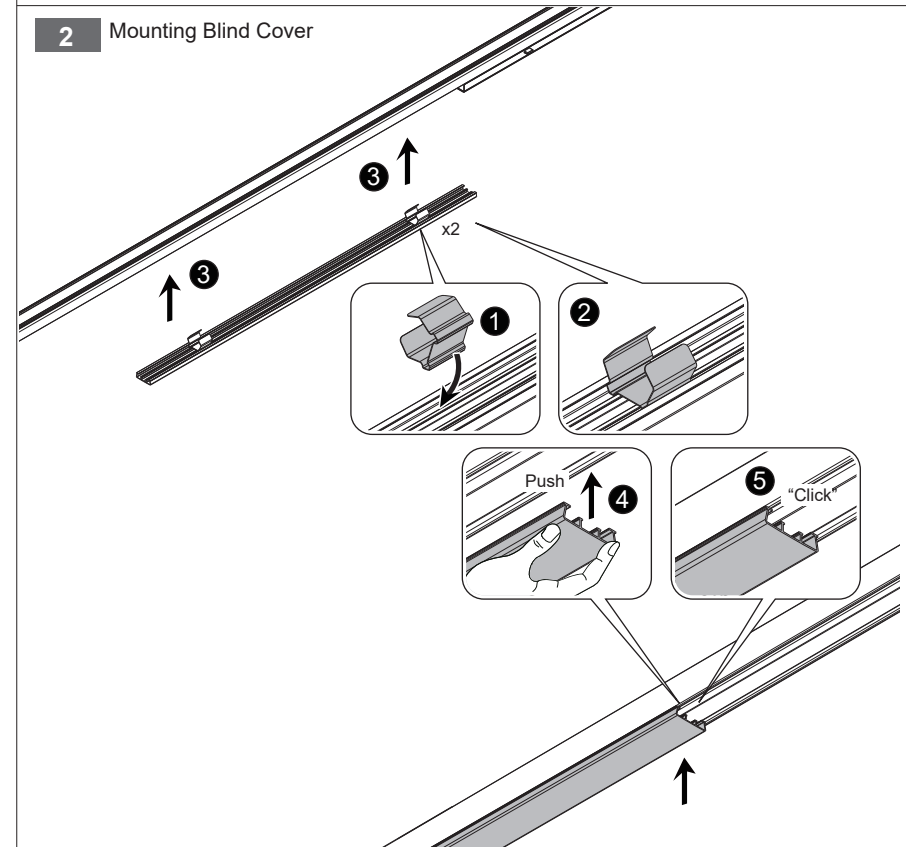

Install extra spring

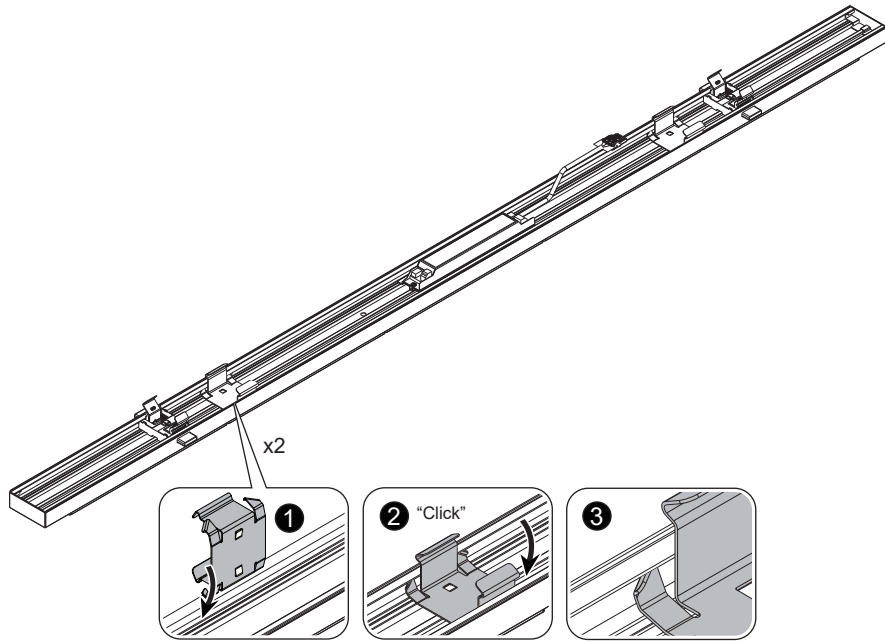

Extra spring compatible list

Picture	Name	Trunk
	Q-STN T8	
	Q-STN T5	
	VLG T5	
	VLG T8	
Picture	Name	Trunk
	DUS	
	5LJ908..	

Dimensions

[mm]

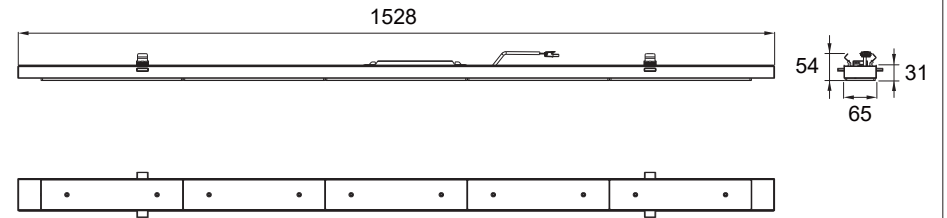

Installation Steps

1

Please check existing label on the old system, and find the corresponding model in the compatibility list.

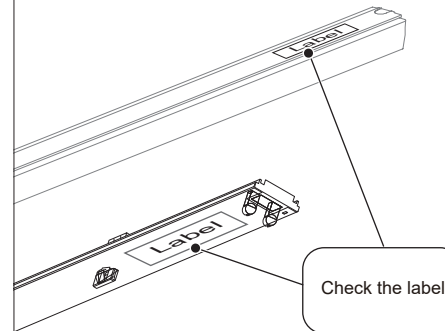

2 Remove old part

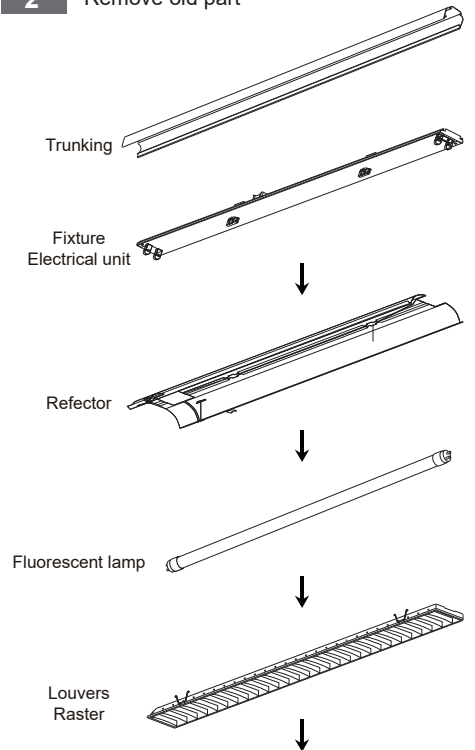

Installation Steps

- 3** Before installation, please cut the tension straps to ensure that the pressingspring is in a released state

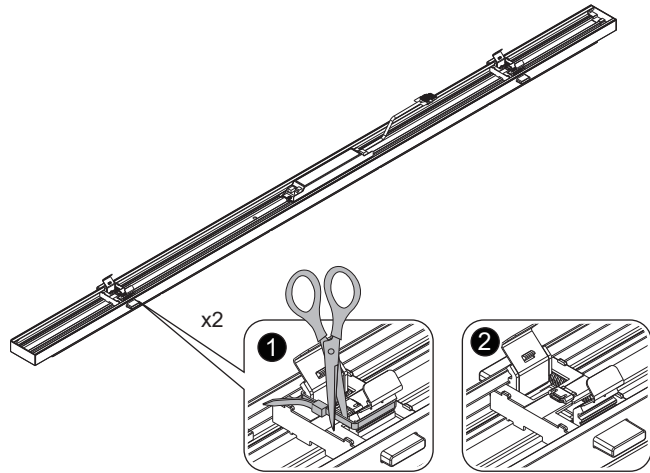

- 4** Wattage & CCT setting (Option)

mA	Power(W)
550	75
500	68
450	61
400	54
350	46
300	40
250	33
200	26



It is not allowed to switch CCT switch under live state

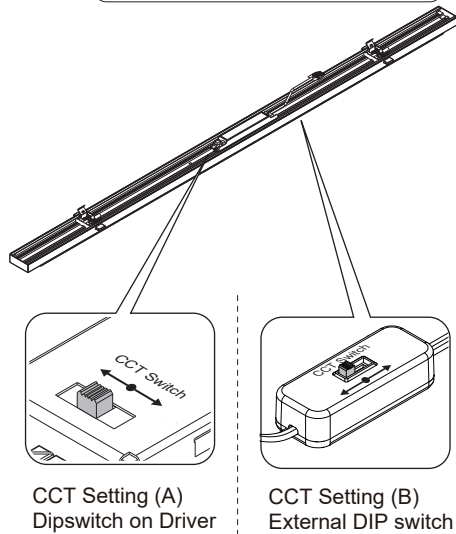

Installation Steps

- 5** Connecting Power Supply

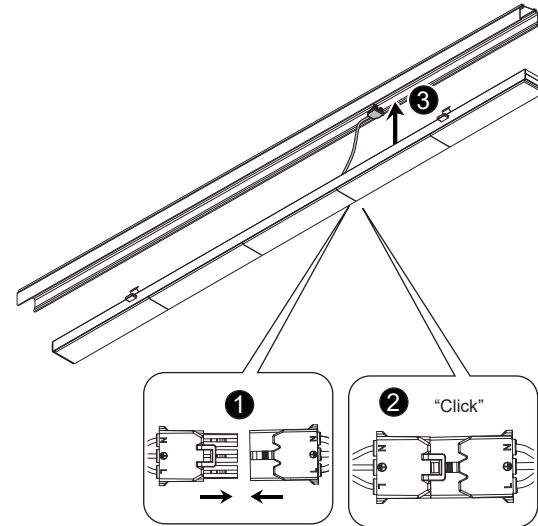

- 6** Mounting the LED module

